

Kent County Organists' Association



February 2021 Journal

FORWOODS MUSIC BY MAIL

First choice for printed music and accessories

15% Discount for KCOA members

call or quote 'kcoa' online

May I take this opportunity of thanking you for your polite and efficient service as well as the very pleasant manner you have always dealt with our numerous requests!

F N, Surrey

What amazing service!! The music arrived this morning. Thank you SO much, takes away a bit of stress from this week's teaching.

F G, South Gloucestershire

Directors: S.M. Yarrow & S.J. Yarrow (KCOA Member)



Freephone 0800 072 0354
www.scorestore.co.uk



Kent County Organists' Association

Patron: The Bishop of Rochester

OFFICERS AND COMMITTEE

President

Michael Cooke
39 Douglas Avenue,
Whitstable,
Kent.
CT5 1RT
01227 272427

email: mi37ke2004@yahoo.co.uk

Secretary

Matthew Young
9 Harcourt Drive
Canterbury
Kent
CT2 8DP
01227 767608

e-mail: acqz@btinternet.com

Treasurer

Kevin Grafton
34 Dartford Road
Sevenoaks
Kent
TN13 3TQ
01732 452117

email: kevingrafton@hotmail.com

Journal

Colin Jilks
9 Rosemary Close
Steyning
West Sussex
BN44 3YT
01903 810395

e-mail: colinkjilks@aol.com

President Emeritus

Brian Moore

President-Elect

James Bryant

Deputy Presidents

Colin Jilks
Nicholas King
David Shuker

Elected Committee Members

Berkeley Hill (Serving first year)
Andrew Cesana (Serving first year)
Malcolm Hall (Serving third year)
(There are three Committee vacancies)

Annual subscriptions should be sent to the TREASURER

Notification of change of address and membership matters should be sent to the SECRETARY

Articles and letters for publication in the Journal should be sent to the

JOURNAL EDITOR

Opinions expressed are those of the authors and do not commit either the JOURNAL or the KCOA

KCOA Website www.kcoa.org.uk

Contents

Our President-Elect writes <i>by James Bryant</i>	3
Sevenoaks & Otford	4
St Ethelbert & Holy Trinity Ramsgate	7
Reginald V Hughes <i>by Brian Moore</i>	9
New Members	9
Front Cover <i>by Paul Hale</i>	10
Barker - A Man of Action <i>by Janus</i>	11
Location - location - location <i>by Berkeley Hill</i>	14
A Cautionary Tale - A Fairy Story <i>by Barry Kemp</i>	18
Singing in The Bach Choir <i>by Kevin Grafton</i>	20
The joys of learning to play the organ <i>by Philip Bowcock</i>	23
A short Profile - <i>Berkeley Hill</i>	25

Photographs
Cover: Exeter Cathedral *by Colin Jilks*
(Canon EOS 5D11 24mm zoom lens 10 sec f/22 ISO-200)
Others: *As marked*

Sub Editors: *Nicholas King, Brian Moore & Kevin Grafton*

Set in Hoefler Text
Printed by Jenwood Printers, New Road, Sheerness, Kent.
Tel: 01795 663861

THE KENT COUNTY ORGANISTS' ASSOCIATION welcomes new members with an interest in the organ and its music. Also those who enjoy visiting churches with appreciation of architecture and heritage. Membership of the Association is not based on the ability to play; we welcome equally those who enjoy listening, as well as those who enjoy playing.

Our President-Elect writes

By James Bryant

AS YOU are aware we were forced to cancel planned activities from February 2020 and it was a great disappointment to me personally that we were unable to go ahead in March with the planned visit, I had arranged, to Hastings. However I remain in contact with my colleagues at the two churches concerned and they look forward to welcoming us during this year. After discussion in committee we also hope to run all outstanding cancelled events from 2020 rescheduled for 2021. Please look on our wonderful new website www.kcoa.org.uk for further information and updates.

We know 2020 has been a disappointment, but thank you for your continued support, both financially and in terms of your comments, suggestions and participation in our Zoom sessions. These have proved invaluable for our committee meetings and of course in terms of the wider membership.

For those unfamiliar with Zoom I have been asked to make some observations. The platform is often the first choice for musicians both in terms of teaching and performing as it offers both flexibility and good sound production. Those of you who may have visited the IRCO site will know this well and as I commented at our October 2020 open meeting there is a wealth of excellent material available for all in terms of both practical and theoretical studies. Zoom also has a facility for screen sharing which is useful in webinars and other meetings where documents can be shared and music per-

formed via YouTube etc. One drawback due to latency makes it impossible for musicians to play together and some of you will have noticed this from attempts by choirs and orchestras. The only way of overcoming it is for everyone to record separately and then put their attempts together. The same problem occurs when two people attempt to speak at once which is why many meetings are conducted with the participants' sound muted until someone wishes or is invited to speak. For more information do visit the site zoom.com where you will find much more detailed information in the form of videos and documentation. Registering costs nothing and is a more efficient way of joining meetings.

As I look forward to my term in office my first duty will be to organise our annual dinner in September 2021 and at the time of writing I am delighted to report Gerard Brooks has accepted my invitation to be our guest speaker subject to dates. He will no doubt have much to relate as he continues to be the RCO President in a year of great importance for the organ both in terms of the planned week of activities in April and the IAO gathering and competition in Edinburgh in July at which Gerard is an adjudicator.

In addition to the above I hope to organise some activities for young children, building on a recent initiative in Margate recently highlighted by BBC South East featuring a collaboration between the church and its local primary school. In passing can I highlight our committee member David Shuker's attempts in this direction with his wonderful travelling instrument which allows children to see how the organ is constructed?

I send my very best wishes for a good year and hope to see you all again in person soon!

Review of recent Meetings

Sevenoaks & Otford

VISITING SEVENOAKS in January 2020 we had the good fortune to be allowed to explore Sevenoaks School's new Performing Arts Centre. Although our Past President, Richard Knight, attended the school as a boy, most of us have only seen the 1732 school building façade from the High Street. The school was originally founded in 1432 following the death of William Sevenoke, who bequeathed substantial funds in his will; it is one of the oldest secular schools in England. Today the school, which is now co-educational, has over 1,000 pupils,



Spanish organ by Grenzing *Photo C. Jilks*

with facilities for boarders.

The school's modern buildings and facilities extend on a large site behind the original 1732 building and we visited "The Space" a quite recently completed £13 million Performing Arts Centre with its multi-purpose concert hall, recital room for chamber music, and a recording studio, all carefully sound-proofed from each other. Pupils have access to a plethora of fine instruments including a harpsichord and two model-D Steinway Concert Grand pianos. Alas, an organ was not considered and organ students had to cross to the Parish Church for lessons on a far from adequate electronic instrument.

The school's organ Tutor, Richard Brasier, persuaded the school to consider a small pipe organ, which could be used for teaching. Owing to the multi-use of the building, a small two manual and pedal instrument with mechanical action, placed on a movable platform, was chosen. After approaching several organ builders, the Spanish company *Grenzing* was selected to provide an organ considered suitable for the recital chamber music room, which was the first organ this company had built in England. Although Richard Brasier deemed the instrument more than satisfactory, its specification and design proved to be quite unusual. Its specification is: *Man 1, Régale 8; Man 11, Bourdon 8, Flûte à chem 4, Nazard 22/3, Doublette 2, Tierce 13/5; Pedal, Douçaine 16. Manuals cc-f 54 notes and Pedal cc-d 27 notes.* There are manual to pedal couplers and Manual 11 is divided at middle C with each rank available separately in either treble or bass section. Its wooden case is not unattractive, with its ornately carved pipe shades.

Michael Cooke was the first to try the organ, making full use of the divided key-



1732 Sevenoaks School building

Photo C. Jilks

board and the 16ft Pedal Douçaine, with its short resonator reed pipes adding a buzzing depth. The manual 1 Régale 8ft had the character of a strangled vox humana, its pipes set beneath the main soundboard in an enclosed box with a foot operated "Swell" shutter. Michael certainly produced music from this unusual instrument, displaying prodigious tonal colours and character, although, in truth, because of its limited design, members considered this organ to be perhaps something of a curiosity, rather than a serious instrument.

The next organ we visited was at The Drive Methodist Church, Sevenoaks. Again this was a comparatively new organ, built and installed by *Harrison & Harrison* in 2001. With mechanical action throughout, its design is undoubtedly conventional with a specification providing clear bright flutes, not overly "chiffed", warm yet characterful diapasons and a singing trumpet. Its oak case with its spotted metal diapason bass front pipes is attractive and functional in design.

Kevin Grafton demonstrated the organ for us with music by Whitlock, Howells and Stanley, with a carefully placed television camera projecting his image at the

console on to the large east wall of the church, for all to see. Members were keen to try the organ and others were able to view the organ's interior through a side panel door which had been opened for us. This is an enjoyable instrument, both visually as well as tonally; *Harrison's* creditable construction and considered



*The Drive Methodist Church, Sevenoaks
Harrison & Harrison 2001* *Photo C. Jilks*



1913 Spurden Rutt, Otford Photo C. Jilks

tonal design producing an organ well suited to its task.

Time was perhaps limited as our afternoon tea was being provided for us at the ancient Parish Church of St Bartholomew at Otford where Kevin Grafton is Organist and Director of Music. First we had a good tea in the adjoining church facilities before we were able to appreciate the 1913 *Spurden Rutt* organ with its rather sombre utilitarian case and zinc front pipes. Apart from one tonal change, the organ remains as it was built, together with its pneumatic manual and pedal actions.

Its original Great Dulciana 8ft was replaced with a new Fifteenth stop during the 1989 overhaul, which provides some much-needed brightness on the Great Organ; the specification is now: *Great Organ, 8 8 8 4 2 8; Swell Organ, 16 8*

8 8 4 2 8 8; Pedal Organ, 16 16, together with usual couplers. This organ is undoubtedly Edwardian in sound, with a tonal palette as warm as a plate of buttered crumpets. *Spurden Rutt* was an exponent of this Edwardian tonality; rich, yet unforced voicing with character and individuality, singing strings, rounded flutes and generous diapasons.

Several members extolled the richness of the 8ft stops by drawing them all together resulting in a lush enveloping sound which filled the building. The individual ranks, although smooth in quality, had an engaging interest, although the new Fifteenth added by *Martin Cross* in 1989 fails to fully blend and integrate, needing a touch more languid 'nicking' to lessen a slightly mismatched classical edge.

We must particularly thank Kevin Grafton for, not only arranging the afternoon, but also so admirably demonstrating for us.



Harrison & Harrison Great Organ Photo C. Jilks

St. Ethelbert & Holy Trinity Ramsgate

STORM DENNIS was very much in mind when we visited Ramsgate on 15th February 2020, the calm before the storm on the journey there, but trees on the line caused delays and diversions for those travelling home by train and in poor driving conditions.

We had visited St. Augustine's Church and the National Pugin Centre on 16th February 2019, and our first visit of the afternoon was now to the Roman Catholic church of St. Ethelbert, a light and airy building designed by Peter Paul Pugin. It has a nave, sanctuary and side chapel, with a resonant acoustic. The organist, George Downar, KCOA member since 1955, spoke about the Abbey and the RC presence in Ramsgate. The church was dedicated in 1902 and the organ, built by *Griffin and Stroud of Bath* in 1903, is situated in the west gallery. It is slightly larger than the organ by the same builder in Tenterden Methodist Church – see David Shuker's report in the February 2020 edition of the Journal.

Changes were made to the organ in 2009 by *FH Browne* at the instigation of Mr. Downar. A balanced swell pedal was fitted, a 22/3 rank replaced the Dulciana and a two rank Mixture the Clarionet on the Great. The specification is now: *Great 8 8 8 4 4 2 22/3 11 Swell 8 8 8 8 4 8 8 Pedal 16 8 usual couplers including Swell octave to Great.* It now has a full and vital chorus, and in the generous acoustic is more impressive than the specification might suggest. Members very much



Griffin and Stroud 1903 Photo C Clemence

enjoyed playing the organ.

The wind was rising as we made our way to Holy Trinity Church, where we were met by Stephen Ansell, Director of Music. He opened his demonstration of the organ with a John Stanley movement, played on the Choir Gedackt and 4ft Prestant followed by parts of the Bach *Prelude and Fugue in C minor BWV 549*, first using a secondary baroque style chorus based on the choir, plus swell 16ft reed coupled to the pedal, and then the Great chorus plus pedal reed. Both were clear and convincing. Stephen then chose the opening of *Le Banquet Céleste* by Messiaen, with Swell strings against the prominent pedal part which requires high pitched manual stops coupled through, to suggest the sound of falling drops of water. Again, very effective, all showing the versatility of the organ, originally built in 1866 as a 2-manual and enlarged in 1961 and 2002 by *FH Browne*.



Holy Trinity Ramsgate F H Browne console Photo C Clemence

Its specification is: *Great Organ, 16 8 8 8 4 4 2 2/3 111 111 8 8; Swell Organ, 8 8 8 8 4 4 2 111 16 8 8 tremulant; Choir Organ, 8 8 4 4 2 2/3 2 2 13/5 11/3 11 8 8; Pedal Organ, 32 16 16 16 8 8 4 16 8 4 16 8 4 4*. There is some discreet inter-manual borrowing and extension, solid state electric action, and full range of couplers and pistons. The console is placed behind the choir stalls and the pipework at the back of a very deep gallery, under which is a substantial hall with kitchen, etc. Nevertheless, the organ speaks powerfully into the church.

Members were very keen to play. Among others, new members Stephen Banfield played part of the Bach *Trio Sonata in E flat*, and Thomas Winrow-Campbell, aged eleven when he won the second prize in the Elementary Class at our 2019 Organ Competition, played a section of the *Tuba Tune* by C.S.Lang. His father has also joined the Association to act as chauffeur. Patti Whaley made us all smile with her infectious playing of the quasi-JSB *Chorale prelude* by Healey Willan *on a melody by Melchoir Vulpius*, and *Variations on Amazing Grace* by Dom Bédard.

After a lovely tea served by the church ladies, the choir of Holy Trinity and KCOA members directed by Stephen Ansell sang Solemn Evensong and Benediction. The music was: Ferial responses, Canticles: S.S. Wesley Chant setting in F, Psalm 47, Anthem: *Lead me, Lord* - S.S. Wesley and two hymns.

As our reporter had to leave following tea, Matthew Young kindly sent this further report by email: A good job you got away when you did. By the time the service was over, 'Storm Dennis' had caused the knock-on effect of the closure of the Ashford to Ramsgate line with widespread delays and cancellations (otherwise known as chaos with no-one knowing anything). At one point there was a replacement bus showing on the display at Ramsgate station, but it disappeared from the screen just before it was due to arrive. For the four of us from Canterbury, the usual twenty minutes to Canterbury West became three hours to Canterbury East, via Dover. Yes, I confess, I was the organiser for the outing, but I did not organise the weather!

The two hymns were accompanied by

Stephen Banfield; Matthew Young accompanied the psalm and the anthem; Ben Crick accompanied the canticles, and Andrew Cesana played us out with an improvisation on St. Clement (the tune of the last hymn: *The day thou gavest*).

There were enthusiastic comments from the Holy Trinity folk, who would be delighted for us to return at any time (even next week!)

Reginald V Hughes BMus

18th March 1932 – 26th March 2020

President 1975-6

A Tribute by Brian Moore

I FIRST met Reg, as he was always known, in 1970, when he invited me to become Assistant Organist on his appointment as Organist and Choirmaster at All Saints', Maidstone. He had moved from Gosport with his wife Peggy and their children Jane and John in 1968 to become Director of Music at Maidstone Grammar School. Both the school and church had very strong musical traditions, Peter Moore being his predecessor at All Saints'.

Those were busy years with three Sunday services, civic occasions, choir concerts, and KCOA visits, so I had to learn fast. It was a privilege to work with a professional musician and I am for ever grateful to have had that experience and for the opportunities Reg gave me. He directed the choir with vitality, paying attention to diction, balance, tone and tuning, done with a sense of humour, and keeping an ear on the accompaniment in the many settings of the morning and

evening canticles and anthems by Stanford, Ireland and Howells, among others.

However, all was not serious. Friday choir practice was usually followed by a convivial evening at the Queen's Head, Sutton Valence, and a favourite trick was for me to slide off the organ stool during a hymn and for Reg to take over without a break. Sometimes we would change roles and Lionel Marchant would play when Reg was away on a tour with his school choir.

Reg left MGS at Christmas 1973 through the disappointment of losing trebles for the choir after the change in entry for boys from the age of 11 to 13. He moved to become Senior Master at Homewood School, Tenterden, but stayed at All Saints' until 1980. A highlight of those years was a broadcast of *Songs of Praise* in January 1974 and recording for Abbey Records. Finally, he was instrumental in the planning and rebuilding the Lewis organ at All Saints', successfully finished in 1980.

Reg was for a time O & C at Wittersham Parish Church, where he built up the choir so that he could include the *Fauré Requiem* in a concert. In retirement he qualified as a cricket umpire, something of which he was very proud. He and Peggy moved to Wales and then to Staffordshire. Sadly, he had a stroke over two years ago which left him as alert as ever but with impaired mobility, and he died in a nursing home, sadly missed but never forgotten.

New Members

Malcolm Riley - Staplehurst
Philip Horley - Director of Music
Sutton Valence School

Front Cover

Exeter Cathedral Organ

by Paul Hale

EXETER CATHEDRAL has one of the most spectacular historic organ cases in the country. Tall and free-standing, neatly 'waisted', it sits high and proud on the elegant and graceful Screen which divides the Nave from the Quire. *John Loosemore* made the case and organ in 1665 – proudly emblazoning both the date and his name on the east-facing front.

The Exeter organ became famous for having the first 'Double Diapason' in England, the bottom fourteen pipes originally being grouped around the pillars flanking the screen. They survived various restorations in the eighteenth and early nineteenth century (and can be seen in an early photograph) only to be melted down in 1877 during a rebuild by *Henry Speechley*.

In 1891 *Fr. Henry Willis* built a new four-manual, 57-stop organ within the 1665 case, which was raised, with a west-facing 'chaire' case added to house the Solo Organ. Willis added a 32ft open metal Contra Violone along the west wall of the south transept. In 1932-3 the organ was re-actioned by *Harrison & Harrison*, who fitted a new console and revoiced the reeds. Alas, the air-raid which destroyed much of Exeter on 4th May 1942 caused considerable damage to the organ, which was patched up in 1949 and limped on until a further rebuild was carried out by *Harrison & Harrison* in 1965. At this point the organ gained a stirring *Trompette Militaire* – positioned in the "Minstrels' Gallery" on the north side of



Exeter Cathedral John Loosemore Photo C. Jilks

the nave. The Choir was remodelled with mutations and a Cimbrel; the Great lost its 1932 Open Diapason I and gained a second Mixture, and there were some Pedal augmentations.

In 2001 *Harrison & Harrison* added a 32ft reed – horizontally on the north side of the screen – when updating the piston system and replacing the Choir Cimbrel with a Larigot. The following year they augmented the *Trompette Militaire* with a Diapason chorus to help lead nave singing. This work was not, however, to last long before it was deemed an entirely new inside structure was required, preserving only the pipes and console of the existing organ. So it was that during 2013-14 the organ was completely remade in Durham by *Harrison & Harrison*, its new layout allowing for better tonal projection and improved access for maintenance.

One hopes that this beautiful organ will now last a good few decades before requiring any further work!

Front Cover

Exeter Cathedral Organ

by Paul Hale

EXETER CATHEDRAL has one of the most spectacular historic organ cases in the country. Tall and free-standing, neatly 'waisted', it sits high and proud on the elegant and graceful Screen which divides the Nave from the Quire. *John Loosemore* made the case and organ in 1665 – proudly emblazoning both the date and his name on the east-facing front.

The Exeter organ became famous for having the first 'Double Diapason' in England, the bottom fourteen pipes originally being grouped around the pillars flanking the screen. They survived various restorations in the eighteenth and early nineteenth century (and can be seen in an early photograph) only to be melted down in 1877 during a rebuild by *Henry Speechley*.

In 1891 *Fr. Henry Willis* built a new four-manual, 57-stop organ within the 1665 case, which was raised, with a west-facing 'chaire' case added to house the Solo Organ. Willis added a 32ft open metal Contra Violone along the west wall of the south transept. In 1932-3 the organ was re-actioned by *Harrison & Harrison*, who fitted a new console and revoiced the reeds. Alas, the air-raid which destroyed much of Exeter on 4 May 1942 caused considerable damage to the organ, which was patched up in 1949 and limped on until a further rebuild was carried out by *Harrison & Harrison* in 1965. At this point the organ gained a stirring *Trompette Militaire* – positioned in the "Minstrels' Gallery" on the north side of



Exeter Cathedral John Loosemore Photo C.Jilks

the nave. The Choir was remodelled with mutations and a Cimbel; the Great lost its 1932 Open Diapason I and gained a second Mixture, and there were some Pedal augmentations.

In 2001 *Harrison & Harrison* added a 32ft reed – horizontally on the north side of the screen – when updating the piston system and replacing the Choir Cimbel with a Larigot. The following year they augmented the *Trompette Militaire* with a Diapason chorus to help lead nave singing. This work was not, however, to last long before it was deemed an entirely new inside structure was required, preserving only the pipes and console of the existing organ. So it was that during 2013-14 the organ was completely remade in Durham by *Harrison & Harrison*, its new layout allowing for better tonal projection and improved access for maintenance.

One hopes that this beautiful organ will now last a good few decades before requiring any further work!

Barker – A Man of Action

by Janus

ORGAN ACTIONS, dating back to the 1600's and beyond were mechanical, that was all that was available. However once the Victorian age began, a time of rapid growth in population and the size of towns led to an enormous increase in the number of organs and churches being built. In turn the number of organ builders rose and a time of cut throat competition began. As the customers for organs began to demand ever grander (larger and louder) organs the builders adopted various measures. They reduced the percentage of tin in the pipes, since tin was much more expensive than lead (roughly ten times the price), leading to the dull 'leaden' sound of some Victorian organs, and they increased the number of stops along with the wind pressure. This placed considerable strain on the actions. Many organists liked the feel of mechanical organs due to the sensation of 'pluck' at the keys. This sensation comes from the soundboard pallets. There are two forces holding a pallet closed, there is a pallet spring and there is the force of the wind holding the pallet closed. As the pallet begins to open, the wind pressure equalises on both sides of the pallet and the initial wind pressure on the pallet goes. The 'pluck' is the initial force needed to begin to open the pallet. The larger Victorian organs with more stops needed larger pallets to admit enough wind for the

pipes and this together with the increased pressures all led to a much larger force than before in order to begin to open the pallet. The result was a very heavy action and organists with very muscular fingers. The *Willis* organ at All Saints, Hastings is reputed to have an extremely heavy action and it will be very interesting if and when the *KCOA* manage to visit it.

Various attempts were made to tweak the mechanical action to lighten it, this can be done by increasing the leverage at the key, however this increases the key dip and this is of limited applicability and various 'trick' pallet designs were developed where initially only a small part of a split pallet was opened. In 1837, Charles Barker designed, or possibly borrowed, the design for a form of pneumatic assistance to lighten the key action. The original Barker lever met with no great enthusiasm in the UK but Barker patented his action in France and the influential builder Cavallé-Coll used it in his organs. The original Barker lever had no direct mechanical connection between the keys and the windchest pallets and although the 'pluck' sensation was retained, the feel originated from the valves in the Barker machine. You could say that the organist played the Barker machine and the Barker machine played the organ. Barker lever actions were employed on various organs by *Walker*, *Hill* and *Willis*, among others, and it was not long before the ingenious Victorians devised improvements on the original Barker lever design. One well known variation was the *Willis* designed 'floating lever' mechanism. This retained a direct mechanical link throughout but with a

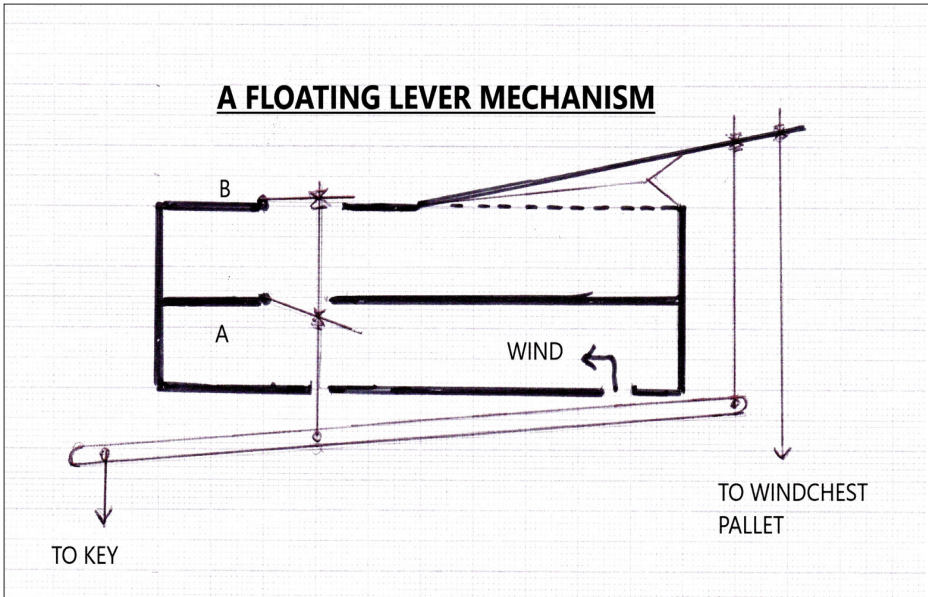
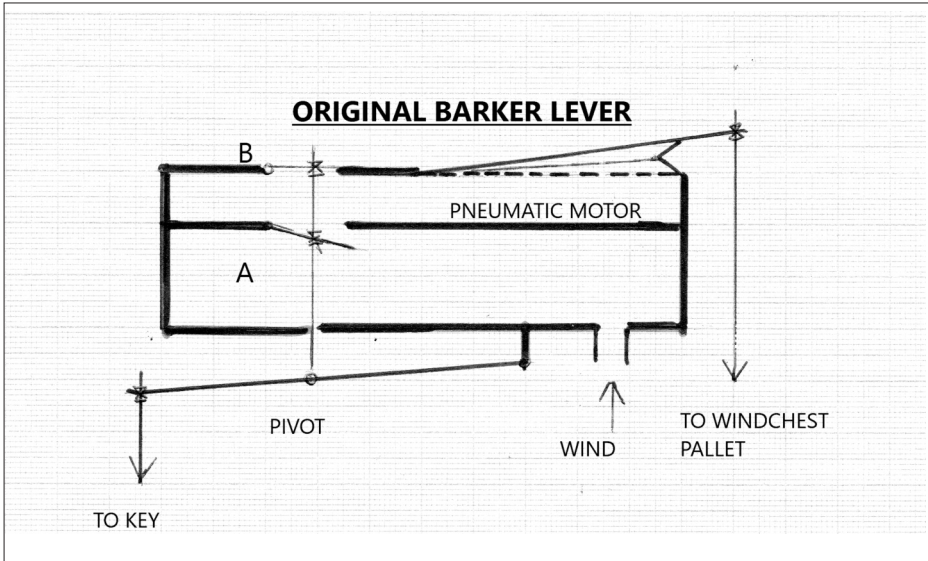

boost from the Barker machine. Quite a few organs built with this system are still playing, although since they employ mechanical linkages and leather pneumatic motors they do degrade in time. The *Walker* organ that the *KCOA* visited at Romsey Abbey had a *Walker* version of a Barker machine. When it became unreliable, probably due to wind leakages, it had the wind pressure increased by *Mander's* to keep it playing. A side effect of this change was that the action became heavier, showing where a lot of the touch originated. This is only a short term measure and it has now been rebuilt (by *Walker*). What with worn mechanical linkages and wind leaks, playing a Barker lever organ has been likened to being accompanied by several typists. Some original Barker lever actions are having the levers rebuilt. A case in point is a church in Falmouth, where the *Willis* organ has had its lever machine returned to the makers for a rebuild.

It was not long before the lever mechanism became out-dated and it was replaced with totally pneumatic actions, electro-pneumatic actions so loved by *Harrison's*, and fully electric actions. These in turn suffer from their own particular age problems and are totally devoid of touch. Once again mechanical action organs are being built and by careful design of the linkages and calculations regarding the size of pallet actually needed, many of the problems associated with over-heavy actions have been overcome; and so the wheel has turned full circle.

In an attempt to demystify the innards of the Barker lever I hope that the diagrams help. They are schematic diagrams to show the working principle involved. Basically there are two interconnected valves, a pneumatic motor and connections to the key and to the



*Romsey Abbey 1858 J W Walker
with Barker Lever actions* Photo C. Jilks

windchest pallet. The valves are arranged so that when valve 'A' is open valve 'B' is closed and vice versa. The floating lever diagram shows how the scheme has been extended to include a mechanical connection to the pallet. The diagram has been simplified and omits most of the springs and adjustments. In the case of the floating lever the pneumatic lever is not required to provide all the force to open the windchest pallet; part of this comes from the mechanical linkage. Of course the diagram shows only the mechanism to play one note, the whole Barker machine consists of 55 to 61 levers, arranged like a chest, and surrounded by a forest of linkages.

Location – location – location

By Berkeley Hill

ORGANISTS are often dreamers, and many a sermon has been spent fantasising on the ideal specification or wondering how it might be possible to relocate the existing instrument to a more effective position. What would be the optimum if no physical or financial constraints applied?

For an Anglican parish church with a traditional layout and a choir housed in the chancel (as many still are), I suggest the key characteristics are the organ's capacity to be used to:-

1. Accompany congregational hymns. For this to be done in a way that enables people singing in the nave to hear the organ clearly and to allow the tone to be varied to suit the mood of the words and the historical period of the tune, the pipes must be reasonably close to the congregation;
2. Play voluntaries from a wide range of periods and styles, with sounds that project well even when only quiet ranks are being used;
3. Accompany the choir singing in the chancel, giving adequate support while simultaneously providing a good balance for the listening congregation in the nave.
4. Give the organist a good idea of how the music sounds from where most people are sitting.

The first two are probably best served by an organ located at the west end of the nave, preferably elevated in a gallery. For its choir accompaniment role the organ needs to be close to the singers in the chancel, but again somewhat raised up if possible to give the sound some room to develop. There are too many churches where the organ is buried in some former chapel in the chancel, with the result that, to make an impression for hymns in the nave, it has to be played at volumes that deafen the choir. A 'blast from the East' is likely to be unpleasant or ineffective, depending where you are sitting.

What would be the ideal solution? Two organs, one in the nave and another in the chancel would require two players or an uncluttered migration route and a nimble organist. More practically, an optimum might be a divided instrument consisting of two parts each of which



The 1936 west end organ, Hythe Photo by B Hill



Set high in chancel a two-manual and pedal instrument of 13 speaking stops, including a 16ft reed

Photo by B Hill

could operate convincingly by itself but which could be played together to provide a sort of surround sound. This means a single mobile console positioned to give the player the best aural messages; this will always be a compromise, but at least there is the possibility of changing position according to need.

St Leonard's Church is in the fortunate position of having an organ that meets these 'ideal' requirements to a high degree. The present instrument was built in 1936 by *Harrison & Harrison (Durham and London)* but incorporated pipes from the church's previous two organs. A few came from an 1812 instrument by England that had stood on an 18th century gallery at the west end of the nave, backing onto the church tower. The 'charity children' who formed a choir were also placed there. Following the Victorian restoration of the church and the installation of chancel choir stalls in line with Oxford Movement preferences, in 1878 *J W Walker and Sons* installed a two-manual organ in the chancel south

aisle, behind the *decani* choir stalls and some nine steps above the nave floor level. Though of good quality, to the congregation in the nave (including the army contingent from the town's Small Arms School) the organ sounded rather distant.

In 1936 the situation was, in principle, resolved by a new organ, a gift to St Leonard's Church by two local businessmen; Mr G L Mackeson was proprietor of the town's brewery that produced the milk stout carrying his name, and Mr E Osbourne owned the Hythe Cabinet and Joinery Works (which constructed the case). It cost £3000 at the time. Their advisors were eminent - Sir Walter Alcock (organ) and Sir Charles Nicholson (casework). They chose *Harrison & Harrison*, who had just completed the instrument in King's College Cambridge. Hythe's organ was the last voiced by Arthur Harrison, as he died before the next instrument he was working on (Westminster Abbey) was finished.

This 1936 organ restored the main instrument to its former nave position

behind the congregation in a specially constructed west-end gallery (the old one had been removed by the Victorians) with room for congregational seating below. Much of the *Walker* pipework was reused (rescaled and revoiced by *Harrison's*), but with additions including an enclosed Choir (in effect, an entirely new Solo section). The 16ft pipe towers and imposing oak case (reputedly from reclaimed ships' timbers) extend almost to the ceiling and dominate any view from the east end (a recent DAC visitor commented that permission to install it today would probably not be granted).

The romantic west-end organ (of three manuals and pedals, with 31 speaking stops) is still very effective, and its impact on listeners is direct and immediate. This part of the organ can be very loud, and visiting organists need to be warned! Although cleaned twice since its installation, care has been taken to keep the voicing as Arthur Harrison left it, though two stops have been added to the Great (a three-rank mixture, by *Kenneth James*, and 4ft flute by *F H Browne and Sons*) to fill rather obvious gaps in the stop-list – the generosity of the original donors clearly had its limits, which also resulted in a somewhat simplified case by eliminating a proposed protruding Chair. The present stoplist is: *Great 16 8 8 8 4 4 22/3 2 111. Swell 8 8 8 8 4 111 16 8 8. Choir 8 8 8 4 8 8. Pedal 16 16 16 102/3 8 8 16.*

To help accompany the choir in their stalls by 'carrying the sound forward', *Harrison* installed in the chancel, high up in the triforium on the north side, an unenclosed one-manual division comprising three 8ft stops, two 4ft stops, plus a 16 pedal rank. Despite the best intention, this only worked in a very limited way, and use of the west end Swell reeds to add colour to accompaniments drowned out the singers when heard from the

nave. In the 1970s and 1980s *Kenneth James*, the London representative of *Harrisons* (who subsequently set up independently and whose father had worked on installing the organ as part of the *Harrison's* team) experimented with the specification of this section by pipe substitution, eventually adding both a 2ft and a two-rank mixture. The rebuild of 1991, necessitated by water damage in the 1987 'hurricane' to the original cabling, gave the opportunity to add a Swell division to the chancel organ and revise its unenclosed division to include mutations, making it a versatile two-manual and pedal instrument (13 speaking stops, including a 16ft reed). It is capable of a wide range of accompaniment roles, even those needing a 'full-organ' sound, while still enabling the congregation to hear the singing choir. It can also be used for organ music requiring a less weighty flue chorus than that of the nave organ. Flexibility is enhanced by all the chancel Swell stops having an extra top octave of pipes for use with the couplers (and unison-off). *Great 8 4 22/3 2 13/5; Swell 8 8 4 11 16; Ped 16 8 16.*

Both the west end and chancel sections are played from the single three-manual mobile console, and the two can be used together or antiphonally (via a transfer stop of 1991 that moves both chancel sections to the Choir keyboard). The 1936 siting of the oak-encased console, in the chancel behind the south choir stalls, was never ideal, with the player unable to hear clearly the main west-end organ because of the intrusion of a large pillar belonging to the chancel arch. At the opening recital the visiting organist (Dr George Thalben-Ball) was reported to have abandoned some of his intended programme because of the difficulty of hearing. Turning it by 90 degrees was tried but barely helped. This hearing issue remained a problem until 1991,



The console on a mobile platform, normally sited in the South Transept Photo by B Hill

when the console was made mobile and relocated to the nave floor level. It is normally sited in the South Transept, within uninterrupted earshot of both sections and about equidistant from each, but migrates to the nave south aisle when there is no singing choir in the summer, and for recitals is moved to the centre of the chancel steps.

So, overall, Hythe's organ seems to be almost 'ideal' for parish use. It serves its liturgical and accompaniment purposes well. For recitals, sounds can be found appropriate to most school of composition (though French music has to put up with a rather Edward Heath-like English accent, as the reeds are quite smooth). Sight-lines for seeing a choral conductor in the chancel are restricted, though a CCTV helps. Alternative plug-in points for the optical-fibre transmission system enables the console to migrate for concerts, and it even goes half-way down the nave for services in August, when there is no choir.

A progressive maintenance programme has seen much re-leathering and replacement of aging swell engines. In 2015 a lightning strike on the West Tower destroyed parts of the electrical workings of the organ, necessitating a complete replacement of the mechanism with the latest digital transmission system and stepper, funded largely by the insurers.

Visitors who would like to test my account of this organ and its location are very welcome to contact me.

Biographical note: Berkeley Hill is Director of Music, St Leonard's Church, Hythe, Kent.

Professor Berkeley Hill BEM (Emeritus Professor of Policy Analysis, Imperial College London) has been the organist and choirmaster at this church since 1972. He was Musical Director and Conductor of the Folkestone Choral Society for 40 years, to 2017. He received a BEM in the 2018 Honours List for services to music in Kent.

A Cautionary Tale - A Fairy Story

By Barry Kemp

ONCE UPON a time in a far-off land (well not that far, actually, a few miles east of Rochester) there is an establishment, built of stone, ruled by a Mighty Wizard and three Glamorous assistants.

Every week, the people of this far-off land congregated in this establishment to sing praises to their God in a time-honoured and traditional way; singing hymns and listening to beautiful music sung by the choir and played by the organ-grinder, a highly qualified and eminently capable musician.

It came to pass that after a couple of years after he arrived in this far-off land, during which he was everybody's friend, the Mighty Wizard saith unto his glamorous assistants, "We need to encourage more of the people to sing praises unto our God. We need to make our gatherings more inclusive."

The chief glamorous assistant replied unto the Wizard, "What a wonderful idea. Why don't we just change the style of the music and the times of the services?"

One of the other glamorous assistants saith, "What will happen to our organ-grinder who hath been playing the organ for half of his lifetime?" "He will have to go!" the others replied in unison.

The Mighty Wizard and the three glamorous assistants went into a huddle to explore ways of removing this impediment.

"I know", saith the chief glamorous assistant, "We will give him an ultimatum that he could not possibly accept, for to do so would be deemed as such a great insult."

"Whoopee!" they all cried, "you are so wise. After all, he does not have a written contract so it cannot, therefore, be terminated. We will allow him to grind the organ but we are just not going to pay him for doing so. In addition, we can give him the status of a 'volunteer'. That will solveth the problem in a stroke."

When the organ-grinder receiveth the ultimatum in a phone call, he was not well-pleased. "Thirty-five years of loyal service to be brushed aside in a mere 35 seconds did not seem to be very fair", he thought. So he consulted the Oracle which referred to the relevant section of the Canon Law. "Aha!", it saith, "Verily, even so, I saith unto you. Canon B20 states that any agreement with the authority, whether written or verbal, constitutes a contract and you are, therefore, subject to the normal employment laws of the land, especially the part which states that any dismissal must be fair".

The Wizard and his Glamorous assistants were not happy when they learned of this. They went into another huddle and came up with another wheeze.

"Aha", they saith, "Let us call him a 'worker' and not an 'employee', for this will restricteth his workers' rights."

Again, the organ-grinder consulteth the Oracle which saith unto him, "the category of 'Worker' only came into being in 2019. This implies that prior to 2019, you must have been an 'employee' and your employer has an

obligation to inform you, in writing, of any change of status.”

Once again, the Wizard and his Glamorous assistants were not happy, they were very cross indeed, as they went into yet another huddle. “Bah, Humbug”, they muttered, “What can we do next?”

“I know”, the Chief Glamorous assistant saith, jumping up and down with glee, “We will give him the status of ‘Contractor with a Service Level Agreement’, that will doeth the trick.”

So, yet again, the organ-grinder went back to consult the Oracle which saith unto him, “No! This cannot be the case because, firstly, a contractor would be Self-employed, and you are not, as you are registered with HMRC as an ‘employee’, as stated on the numerous P60 forms you have receiveth over the years, and secondly, no Service Level Agreement has ever been seen.”

The Organ-grinder spoke to an independent person of a rank higher, even, than that afforded the Mighty Wizard. He saith unto him, “Would you arrange a meeting between you, me and the Wizard, with his Glamorous assistants?”

To which the independent person of a rank higher, even, than that afforded the Mighty Wizard, saith, “Yea, verily even so, that is a good way forward and we will see if there is a peaceful solution”.

The independent person of a rank higher, even, than that afforded the Mighty Wizard, wrote to the Mighty Wizard and his chief glamorous assistant many times, but has not receiveth any reply that could possibly lead to a resolution. The Organ-grinder is not surprised, and wondereth what the Wizard and his glamorous assistants’

next ploy will be.

So, fellow Organ-grinders, the moral of this sad *Fairy Tale* is that even if you *do not want* a written contract or even if you *do not think you need* one, THINK AGAIN! No matter how friendly your own particular Wizards and Glamorous assistants may be, they could all be capable of putting a metaphorical knife between your metaphorical shoulder blades, should they so desire. Forget not also that Wizards come and Wizards go, as do their glamorous assistants, and you know not who will replace them.

Obtain a Contract template from the *RSCM* and tailor it to suit your own particular needs. Above all, *make sure it is watertight*.

Be wary of any future contact with my Wizard and his Glamorous assistants residing in that far-off land, for he who sups with this Mighty Wizard and his Glamorous assistants needs an exceedingly long spoon.



Rainham, a tranquil scene Photo C Jilks

Singing in The Bach Choir

By Kevin Grafton

THE BACH CHOIR is special: not only special to all its members, but also to its supporters, in its organisation and in its history. It is my privilege to be a small part of that history.

The Choir was formed for the first complete performance in Britain of J. S. Bach's *B Minor Mass*, which took place in 1876. The man behind the idea, and the Choir's first conductor, was Otto Goldschmidt, husband of the famous soprano Jenny Lind, the 'Swedish Nightingale'. It now seems extraordinary to us that such a major work was not performed in its entirety in this country until more than 125 years after its composition, but of course Bach's music in general was not well known here until its revival by Mendelssohn in the early 19th century.

Having successfully completed its mission, the Choir decided to carry on singing, and is now in its 140th season. The object of the Choir is 'the rehearsal and performance of choral works of excellence of various schools.' This rule has remained unchanged throughout the life of the Choir.

To begin with, the Choir drew its members largely from the upper classes, as evidenced by the fact that rehearsals – largely optional in any case – were held during weekday afternoons. The Choir now consists of over 220 people from all walks of life, rehearses every Monday evening, and enjoys an excellent reputation.



Musical Director, David Hill Photo Bach Choir

A review in the Evening Standard a few years ago called it 'probably the finest independent choir in the world', and a review of our most recent concert (Walton's *Belshazzar's Feast*) said that 'on this deeply impressive showing, the Bach Choir has no equal – diction, intonation, phrasing and dynamic characterisation: it was impossible to imagine finer choral singing than this.'

Such reviews are not earned without hard work and great attention to detail on the part of our Musical Director, and David Hill is the present incumbent, rehearsing the Choir on a weekly basis as well as fulfilling his other duties as Chief Conductor of the BBC Singers, Associate Guest Conductor of the Bournemouth Symphony Orchestra, Chief Conductor of the Southern Sinfonia, Music Director of Leeds Philharmonic Society and Principal Conductor of Yale ScholaCantorum. His energy and commitment seem boundless, and one of the reasons why the Choir is special is that not only does he rehearse the Choir but he also normally conducts our concerts. Many of the large London choirs are rehearsed by a repetiteur but conducted in perform-

ance by another prominent conductor engaged by the orchestra which promotes the concert. Although we do carry out some such engagements – having been conducted by such as Charles Mackerras, Richard Hickox, John Rutter, John Pritchard etc. – almost all our main concerts are promoted by the Choir and conducted by our Musical Director. This gives a continuity of interpretation between rehearsal and performance which is difficult to match.

In its 140 year life, the Choir has had only nine Musical Directors, of whom the last three have served for a total of 85 years. The complete and distinguished list of previous Musical Directors is: Otto Goldschmidt, Charles Villiers Stanford, Henry Walford Davies, Hugh Allen, Ralph Vaughan Williams, Adrian Boult, Reginald Jacques and David Willcocks. The last in particular, with his experience at King's College, Cambridge, was responsible for inculcating high performance standards and introducing 20th century British repertoire.

The Choir has enjoyed royal connections over the years. For many years the Patron was HM The Queen, and when she cut down on some of her many patronages, Prince Charles took over. He has himself sung in the choir, though this was now over thirty years ago. The Duchess of Kent was in the sopranos for several years, and we have often given performances for the royal family, the peak of which was singing at the wedding of Prince Charles and Lady Diana Spencer in 1981.

We have some six to eight 'core' concerts per year, principally in the Royal Festival Hall, plus a number of other engagements which frequently do not

use the whole choir. For instance, this year we have a total of seven carol concerts to choose from!

It is a common misconception that the Choir sings exclusively Bach. In fact, the one Bach work which we perform every year, and have done without exception since 1930, is the *St Matthew Passion*, sung in English. Otherwise, the *B Minor Mass* understandably makes periodic appearances, as does the *St John Passion*, but no other Bach works are frequently performed, as 'authentic' performance practice these days is very much against large choirs singing Bach. The Choir has always been committed to music of all periods from Bach onwards, but much of its repertoire is 19th and 20th century. The Choir has given many first performances, and recorded works ranging from Britten's *War Requiem* (the classic first recording) to Howells (*Hymnus Paradisi*, *Stabat Mater* etc), Vaughan Williams (*Sancta Civitas*, *Dona nobis pacem*) David Matthews (*Vespers*), Delius (*A Mass of Life*), Carl Rütli (*Requiem*), and Bob Chilcott (*The Angry Planet*), as well as two recordings (1948 and 1978) of the *St Matthew Passion*.

All of this, even though it is important to know something of the background of the Choir, is really a prelude to a description of what it is to belong to the Choir. At the first rehearsal of any work, we are expected to sing the right notes; to that end, the standard of sight-reading among Choir members is exceptionally high. This means that subsequent rehearsals can be concerned with style, phrasing, breathing, pitch, clear enunciation etc. After weeks of painstaking rehearsal, to stand and sing amongst all the other members and to know that one has



The Bach Choir

Photo Bach Choir

given one's best possible performance is reward enough in itself, and then to hear the audience applauding long and hard, and cheering as the Choir comes to its feet for another round of applause – it is so hugely satisfying that words fail.

I have now sung in the Bach Choir for 42 years, during which time I have gained many friends. Many of us who commute to London prefer to go straight home after rehearsals, but there is a friendly group of those who favour a pint or two before wending their way home. I have found that being on tour is the best way to get to know people, and though circumstances have prevented me from going on most of the longer tours the Choir has undertaken in recent years – to America, South Africa and Australia – I have had the privilege of travelling with the Choir to France, Germany, Sweden, Norway, Israel and Hong Kong, taking British music abroad and, in many cases, hearing the best of the host country's own performers.

Tours produce their own memories: getting to know the delights of drinking kir in a late night meal provided by French monks in Royaumont Abbey;

the Christmas visit to the armed forces in Germany, when all the travel arrangements went so spectacularly awry that we did not have time for one rehearsal throughout the entire tour – we were so late arriving, due to fog, that a police escort was given to the Choir coach speeding along German motorways to our first concert; changing for a concert in the gallery at Versailles Chapel, trying not to let the tourists below glimpse half-naked Choir members; the beauty of Stockholm in the snow and of Grieg's house in Troldhaugen in the Norwegian spring; singing for the workers on an Israeli kibbutz and being presented with a single rose each. And a very special memory for the Bach Choir: an impromptu performance of a Bach chorale in the gallery of a church in Eisenach, looking down on the spot where JSB was baptised in 1685 – I would not have missed it for the world.

*This article was first published in 2016 in
Tempo 16 - the magazine of Mensa's
Classical Music Special Interest Group.*

The joys of learning to play the organ

By Philip Bowcock

I BELIEVE THAT the first time I heard an organ was at my baptism at the age of six months. While I cannot recall the event I always like to think that the church had a very good instrument which was the 'show piece' for prospective clients of the builder, *Charles Whiteley & Co*, and this had an influence on me later.

Be that as it may, my grandfather was a Congregational minister so it was only natural for my mother to take us to one of their churches. Here they had a small organ, two manuals, pedals, and three stops on each, nearly all 8ft with 16ft pedal bourdon and just one rather quiet 4ft flute on the swell; nothing exciting. However the organist was very good and I used to like listening to him playing. At the time, he sometimes played the Bach *G minor Fantasia and Fugue* which really caught my imagination, so my wish to learn the organ really took off. On one occasion something went wrong with the organ and so after the service he needed to take a panel off, and I always used to have a screwdriver in my pocket because I liked to take things to pieces. I helped him do whatever was necessary, so my first organ lesson was that the organist always needs a screwdriver!

I later started piano lessons with my School Music Master, Alfred Robinson (AR) who was also Organist to the Duke of Westminster. AR himself had a very interesting background. His father was a worker on the Duke's Eaton Hall Estate and on one occasion AR, a young lad at the time, played the piano at a concert in the Eccleston village hall. The Duke and

the Duchess were present and afterwards she said to her husband, 'You really ought to do something for that boy', so they paid for him to go to the King's School and then to University, before returning to Eccleston and Eaton Hall. They certainly looked after their staff in those days.

I eventually started to take a more practical interest in the Congregational church organ and on one occasion, having the organist's permission, I had started to play it when the Minister came in, and he said that it was a 'church thing' and I was not to touch it. I didn't take much notice after he had gone!

Later on, after I had reached about Grade 5 level, (though I have never taken any exams), AR started me on the organ, although I didn't make much progress for a long time because of my work on professional examinations. Some time after that the Congregational organist left and by that time I was just about competent enough to take over. Being taught by AR of course meant that I could also practice on the *Gray & Davison* organ at Eccleston Parish Church, about five miles away. A lovely instrument (as you might expect at a church supported by the Duke) but the action was rather heavy. This of course involved a Saturday afternoon cycle ride so there wasn't much time left on those days.

After around three years I went to Malcolm Boyle who had been Organist and Choirmaster to Chester Cathedral. Sadly his wife had left him, but that was OK so far as the Powers of the Anglican Brigade were concerned, but when he remarried that was just too much for them and he was sacked. He was a brilliant musician and teacher, but disappointingly he moved to Canterbury after a few weeks and I was passed on to the Sub-Organist of the Cathedral, Arthur

Sutton. This was fine and had the additional attraction that my lessons were on the Cathedral organ, but had the problem that the pedal board was very different from the one on which I was practicing.

As I was having lessons in the Cathedral I was allowed to go in after hours to practise when nobody was around, and could let rip with full organ including the 32ft pedal double trombone, a magnificent sound. A visit however required cycling to Sutton's house to borrow the key (nearly 12 inches long and probably as old as the cathedral itself) and then cycling to the south transept and letting myself and bicycle in. This was in the days after the War, around 1950, when street lighting was very poor and the whole cathedral was in almost complete darkness. Having entered and locked myself in, I had to navigate around all the chairs in the four chapels there, then past the nave altar and under the organ to where there was a single light switch and the key to the spiral staircase to the console, with rather hazardous steps in the dark up to the console, then switch on the lights and the blower and enjoy myself. Coming down and leaving was the reverse, except that after having been looking at brightly lit music, seeing the way was even more hazardous. And by the time I reached ground level all the wind chests were collapsing and creaking and groaning.

At one point Sutton gave me a piece (can't remember what it was) which required a pedal top F. On coming to try this I found that it wouldn't work so what to do? I asked the Tuner to fix it on his next visit to the Congregational church, but he declined, probably thinking that it would take too much of his allotted time and he probably didn't think I would ever use it anyway. So out came the screwdriver again and I looked at the action very carefully and found that the roller had split. Taking it out didn't appear to be much of a problem

but would require that I took off the whole side panel. Not difficult, but opening up the side would make it appear to be a very big job. The next Saturday afternoon I went armed with some more simple tools, took off the panel, unscrewed the roller quite easily, and took it home where, with my father's advice, I strapped up the split, took it back and replaced it and adjusted everything: all worked fine.

Unfortunately, during my absence at home repairing the split, the Church Secretary had come in and seen what to him appeared to be a major dismantling of the instrument, and reported it to the Minister (a new one) who ordered me never to do anything like that again! The need never arose, otherwise he would probably have had my resignation.

By this time I had worked through quite a few of Bach's, Mendelssohn's and several others' compositions, ending with JSB's first *Trio Sonata*, this last being one which requires complete independence between manuals and pedals. Overall, I think I had made enough progress in that church and might have moved on, as Sutton suggested that I should start preparing for ARCO, but in 1954 national service got in the way and then wife and family arrived and I never went back to lessons.

In 2000 I had a call from the Rector of a local church, 'My organist is leaving so could you play for a month while I get applications in?' At the end of the month he said he hadn't had any and could I stay for a bit. I was still there in 2019, and at 86 years of age, playing regularly and enjoying it, but then sadly I broke my leg badly and eventually decided that it was time to decide 'Job done' and passed it over to my deputy. These days, of course, he sadly has very little opportunity to play anyway, with all the Covid restrictions in place.

Philip Bowcock was previously Curator of the Reading Town Hall organ.

Berkeley Hill

A short Profile

BORN on 6 May 1944 at Swindon, Wiltshire, Berkeley came from a musical family. His father was founder and conductor of the Swindon Orpheus Choir, which achieved much success in competitions in the West Country and regularly broadcast for the BBC's regional and world services. Berkeley's first musical memories are of that choir singing Parry's *I was glad* (the B natural on 'glad' especially) and Kodály's *Jesus and the traders*. His father was also choirmaster of a Methodist Church in Swindon, where Berkeley's mother sang. An uncle was choirmaster, for more than 50 years, at the local village Methodist Church where a great-aunt was organist. This great-aunt was fiercely possessive of its pipe organ (a 1938 2-manual by *Martin and Coates of Oxford*) and yielded the organ stool to no-one. Undeterred, and in collusion with his uncle who knew how the wind was switched on, Berkeley undertook clandestine organ practice when his great-aunt was known to be elsewhere. Technique was helped by the temporary housing in the family home of a two-manual electronic destined for a Swindon church. So when the organist of a large Swindon town centre Congregational Church died suddenly, the local network swung into operation and Berkeley, aged 14, was appointed. There was a kindly choirmaster and a

good four-part choir that sang anthems every Sunday and psalms to Anglican chant. The fact that the church lost the top of its bell-tower after Berkeley's first Sunday in high winds could not perhaps be attributed to his playing too loudly, though the choirmaster did suggest that less organ volume might be an improvement. Much of the first of his four happy years there was spent catching up on the choir's repertory, and in practising for lessons with Marc Foster, at Cirencester Parish Church, which involved a seventeen mile cycle ride (in each direction). At the same time he studied the double bass and played in orchestras, frequently out of his depth, but enjoying seeing how conductors worked and gaining experience of what players need.

In 1965, after three years at Nottingham University's School of Agriculture and Horticulture, during which time he deputised at Sutton Bonington Methodist Church, with its fine *Walker* organ, he spent a year teaching at his old school in Swindon, before moving to Reading University to take a PhD in agricultural economics. Reading's music department had an open-door policy and all students could take instrumental lessons at subsidised rates. Berkeley's organ tutor for three years was John Webster who came weekly from University College Oxford. Webster was a fine performer, but a meticulous friendly teacher who laid a sure musical foundation. Berkeley won the university's organ prize but had to give it back as an administrator found, in the small print, that only undergraduates were eligible.



Berkeley Hill

Photo B Hill

In some respects, Berkeley found studying for a PhD a lonely and unfulfilling activity for much of the time. Therefore, in 1968 to give some balance to life, he took an organist job back in Swindon, commuting to Immanuel Congregational Church where there was pressure to maintain its fine musical tradition, and where the former organist had been the music teacher at a local grammar school. The choir training experience was invaluable later, as was acting as assistant conductor of the Orpheus Choir. His double-bass playing continued, including as a deputy in the orchestra of the Royal College of Science, where in the chorus was a girl (Hilarie) he had known at school and who soon became his wife. Somehow all this was combined with a one-day-a-week post at the Royal Agricultural College, Cirencester lecturing in economics, often preparing material for lectures just hours before they had to be delivered.

With his PhD eventually written up and a wife and family to support, a permanent job was needed. Wye College (University of London) advertised a lectureship which eventually came Berkeley's way, after the College's first choice turned it down. The move to Kent in 1970 soon led to his acting as an assistant to Michael Lewis at Ashford Parish Church, with its fine large boys-and-men choir and cathedral-type repertory. In a chance meeting on a street corner, Berkeley learned that St Leonard's Church Hythe would soon be looking for a new organist and choirmaster, as the long-serving Freddie Skinner had died unexpectedly. A letter was sent to the vicar offering to fill in until a replacement could

be found, and this landed on the vicar's desk on the day of Fred's funeral. A stand-in was not needed, but Berkeley was invited to apply for the job, which was advertised. Though the least qualified candidate in terms of diplomas and degrees in music (he still has none), obviously something clicked with the vicar, who had been a choir-boy at All Saints, Margaret St. Also the fact that the organist could be referred to as Dr Hill impressed the PCC even though this was completely irrelevant to the skills required to run the parish's music. The vicar extracted a promise that Berkeley would stay for 2 years; so far he has served for forty-eight.

The church choirs at Hythe have been central to his musical life. The number of boy trebles has fluctuated over the years, from the mid-20s to less than 12, though in 2020 (before the Covid-19 shutdown) it was at its long-term average of 17, with eight men. It is the sole remaining boys-only top line in a parish church in Kent, and an active programme of recruiting is the key, with annual visits to six local primary schools. In the 1980s and 1990s there were some seventeen singing 'holidays' at British cathedrals and several trips abroad, investments that greatly enhanced the choir for the rest of the year, but which became increasingly difficult in terms of risk management. In the late 1990s changes in youth activities meant that the number of boys available on Sunday mornings became inadequate, so an Adult Mixed Choir was formed to sing three mornings each month, the boys concentrating on Evensong. In 2007 the Hythe Girls' Choir was formed to give gender equity, and these sing on the

first Sunday morning Eucharist. Running three choirs, each with their separate programmes, is a logistical nightmare but, Berkeley says, this is the only way to maintain the sort of choral tradition expected at Hythe. There has usually been access to someone to act as assistant organist at Evensong - Berkeley mostly plays at the morning Eucharist - and a local charity has paid for an organ scholar that Berkeley teaches as part of the scholarship; the system has produced three Oxbridge organ scholars, several for other universities, and a number of now-established holders of important parish posts.

In 1976 Berkeley became Musical Director of the *Folkestone Choral Society*, a post only relinquished after 40 seasons in 2017. This choir, of up to 120, performed all the standard choral works, and many less standard, with professional orchestras and soloists. Berkeley found that only when conducting his fourth *Dream of Gerontius* or *Verdi Requiem* or Bach *St Matthew Passion* could true familiarity be achieved. Each season lost about £10,000 on its concerts, although covered in other ways, and the *FCS* gave him conducting opportunities that would otherwise have been impossible to an amateur. As an indulgence, often orchestral items were included in concerts, ranging from piano and violin concertos to overtures by Wagner, Tchaikovsky and Verdi. The experience of being a former double-bass player came in very useful!

From 1978 to 1999 Berkeley also ran the *Wye College Choral Society*, a group of students not initially experienced in choral music but whose youth and intelligence enabled remarkable

progress to be made in works such as the Haydn Masses, Fauré *Requiem*, Britten *St Nicolas*, and the inevitable *Messiah*. Contacts made through the Folkestone Choir enabled orchestras and soloists to be engaged. Lastly, Berkeley founded and still runs the Shepway Singers, a group of twenty-four experienced musicians that specialises in a *capella* music of all periods. Recent projects have included performances of John Joubert's '*St Mark Passion*', American music, including Bernstein, Billings and Brubeck, and '*The Golden Age of Polyphony*' (Byrd, Tallis, Palestrina, Victoria). The chief problem with this group is that the only time members can get together is late on Sunday nights, which is not ideal for an ageing church musician whose day started before 9.00am.

Berkeley regards himself extremely fortunate in having been able to maintain a semi-professional career in music in parallel with his 'day job' as an academic economist, which ended with a personal professorship (in policy analysis) at Wye College. When that institution merged in 2000 with Imperial College London, on 'retirement' in 2005 he found himself made an Emeritus Professor of that top university, another bit of luck which is useful in his continuing consultancy work. On top of that, he was awarded a BEM 'for services to music in Kent' in the 2018 New Year Honours: fortunate indeed.

Blessed with a mischievous sense of humour, Berkeley is undoubtedly an ebullient character, a lovable rogue who exudes a charm and *joie de vivre* wherever he goes, and we are undoubtedly most fortunate to have him as a member of our Association.